



LSYCC3KP-FP



Actual product appearance may vary.

Fully Potted Limit Switches HDLS Non Plug-in; Top Plunger; 1NC 1NO SPDT Snap Action; 12-foot Cable

Features

- Excellent sealing capability for withstanding Harsh Duty food and beverage wash downs and severe machine tool environments.
- Switch cavity epoxy filled
- Extra diaphragm sealing
- 12 foot STOOW-A cable or connector version (other lengths available)
- (Cable versions) NEMA 1, 6, 6P, 12
- (Connector versions) NEMA 1, 6, 6P, 12, 13
- All fluorocarbon seals (low temp. available)
- Exceeds NEMA 6P
- UL Listed, file #E37138
- CSA Certified, file #LR57326

Potential Applications

- Food and beverage machinery
- Conveying equipment
- Automotive machine tools and conveyors
- Pulp and paper equipment

Description

The MICRO SWITCH™ fully potted HDLS provides an extra degree of protection in harsh environments by sealing the basic switch cavity with epoxy. These switches are the same as the non plug-in HDLS except that the entire switch cavity is filled with epoxy in addition to the conduit entrance, and the switches are preleaded, either with cable or connectors. The MICRO SWITCH™ harsh-duty limit switch also requires no adjustment over the life of the switch and provides an all metal drive train, superior sealing which keeps the shaft moving freely, twin fluorocarbon shaft seals, superior corrosion resistance, type 303 stainless steel shaft, anti-corrosion phosphate sealed epoxy finish and a valuable trouble shooting tool - 120 Vac neon or 24 V LED indicators available. The replacement head part number of the switch is metal stamped, so it won't wash off. It also provides a wide variety of operating heads, fluorocarbon diaphragm seal - which eliminates fluid infiltration, epoxied construction, zinc diecast housing, head and body, an additional body seal, fluorocarbon sealed cover and high compression ridge and your choice of termination options. The MICRO SWITCH™ harsh-duty limit switch exceeds NEMA 6P because machine processes and their associated fluids demand more than the standard NEMA 6P switch provides. The switch meets the environmental challenges found in actual automotive production facilities and food and beverage lines. The MICRO SWITCH™ harsh-duty limit switch is made for environments that surpass NEMA 6P test criteria.

Product Specifications	
Availability	Global
Operating Force (O.F.)	17,79 N max. [4 lb max.]
Pretravel (P.T.)	1,78 mm max. [0.070 in max.]
Overtravel (O.T.)	4,83 mm min. [0.190 in min.]
Differential Travel (D.T.)	0,38 mm max. [0.015 in max.]
Product Type	MICRO SWITCH™ Fully Potted Heavy-Duty Limit Switches
Actuator	Top Plunger
Circuitry	1NC 1NO Single-Pole Double-Throw, Snap-Action, Double-Break
Ampere Rating	10 A (Thermal)
Supply Voltage	600 Vac and 250 Vdc max.
Housing Material	Zinc Die-Cast
Termination Type	12 foot Cable
Housing Type	HDLS Non Plug-in
Series Name	HDLS - Fully Potted
Sealing	NEMA 1, 3, 4, 6, 6P, 12, 13
Approvals	UL listed, CSA Certified, CE Certified, CCC Certified
CSA File #	LR57326/Master Contract 152457
UL File #	E37138
Operating Temperature Range	-12 °C to 105 °C [10 °F to 221 °F]
Comment	Actuation: For in-line operation only
Agency Approvals and Standards	EN60947-1, EN60947-5-1
UNSPSC Code	302119
UNSPSC Commodity	302119 Switches and controls and relays
Sealed	Industrial
Operating Position (O.P.)	45,8 mm [1.805 in]

PLUNGER TYPE TOP

SINGLE POLE

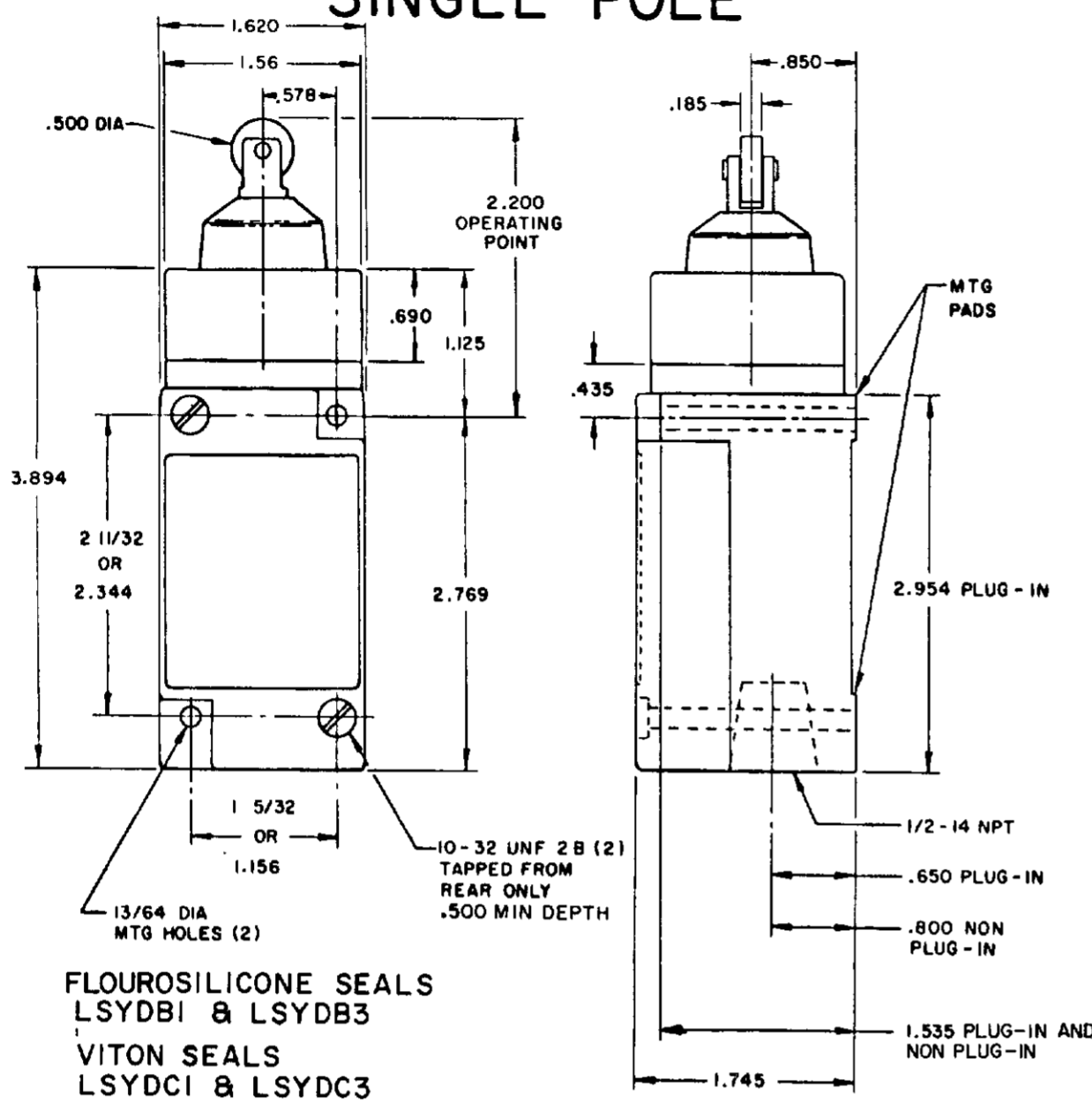

DOUBLE POLE

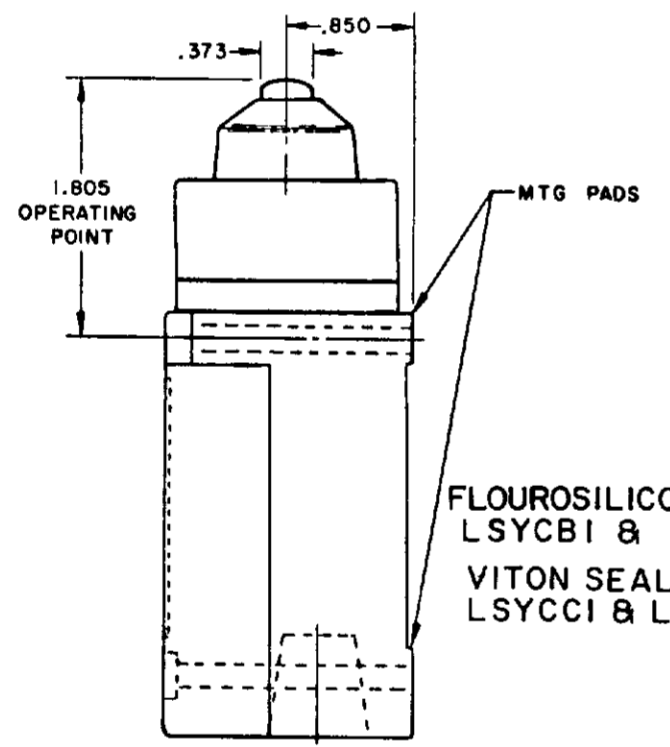
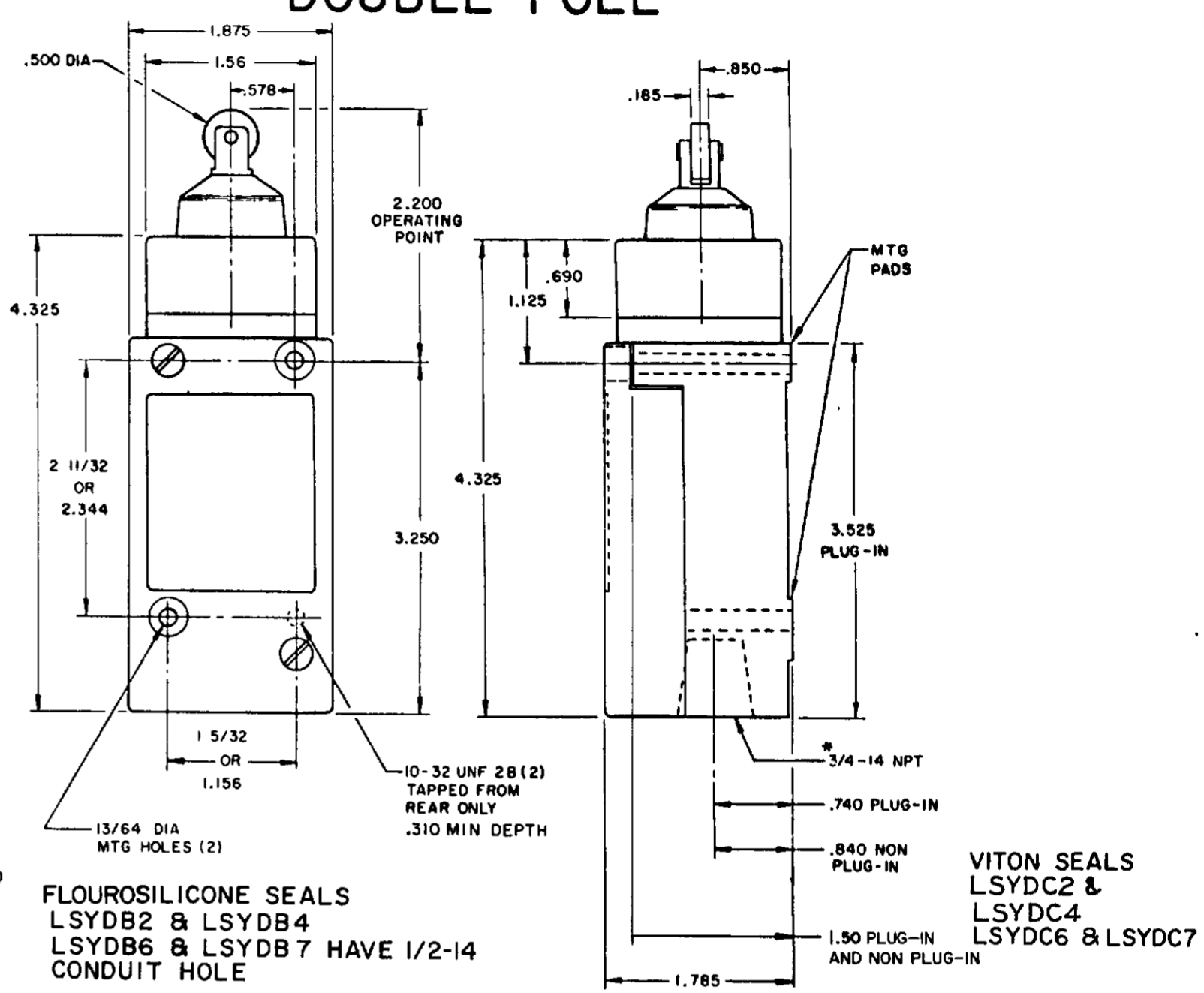

**SINGLE POLE PLUG-IN ONLY
WITH INDICATOR LAMP**

180 X .400 LENS
(FLUSH WITH HOUSING)

120 LAMP VOLTAGE -
LSYCB 5, LSYDB5, LSYVB5
LSYCC 5, LSYDC5, LSYVC5

240 LAMP VOLTAGE -
LSYCB8, LSYDB8, LSYVB8
LSYCC8, LSYDC8, LSYVC8

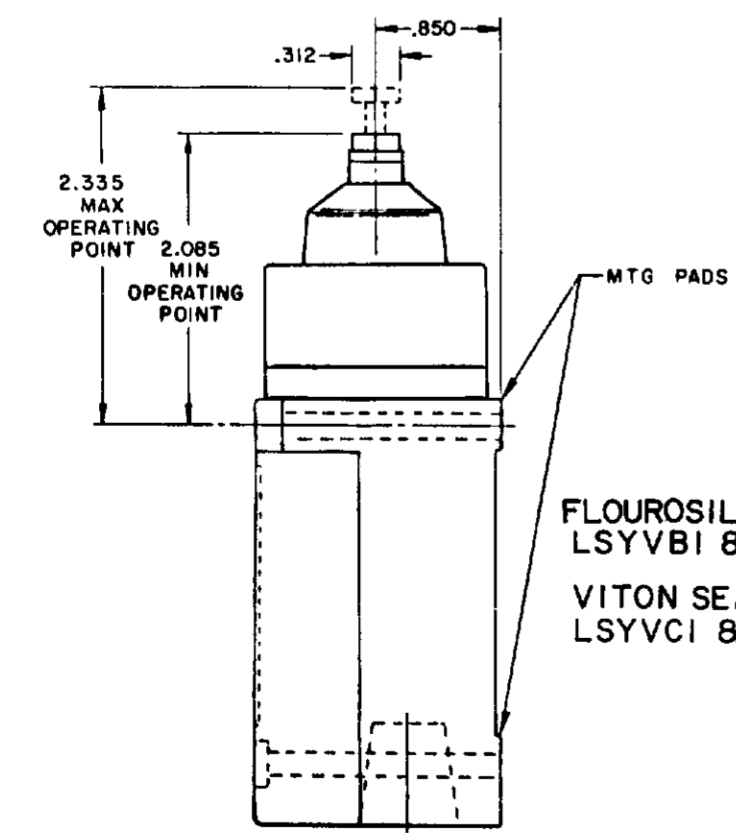
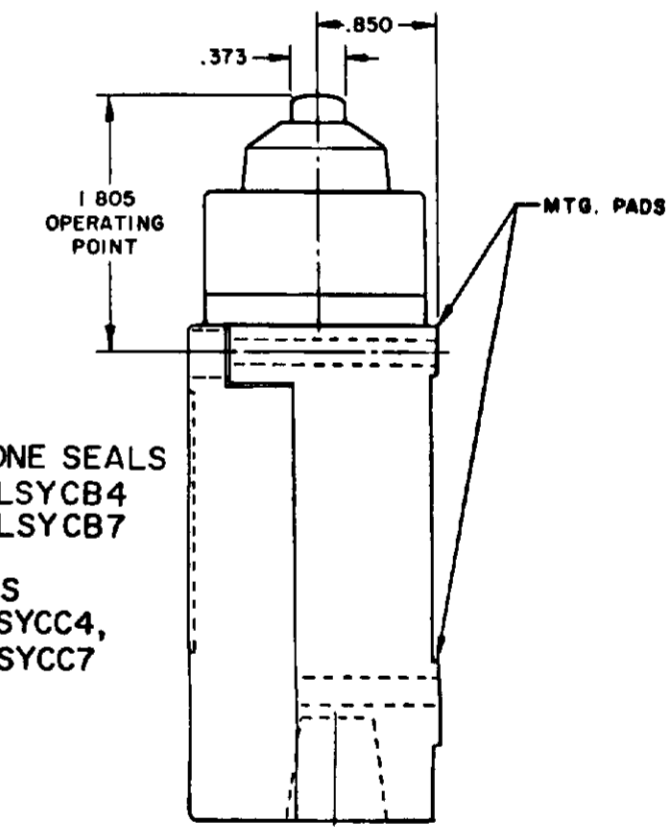

**MANIFOLD MOUNT (PLUG-IN ONLY)
SINGLE POLE AND DOUBLE POLE
TYPE LSYA THROUGH LSYW SERIES**

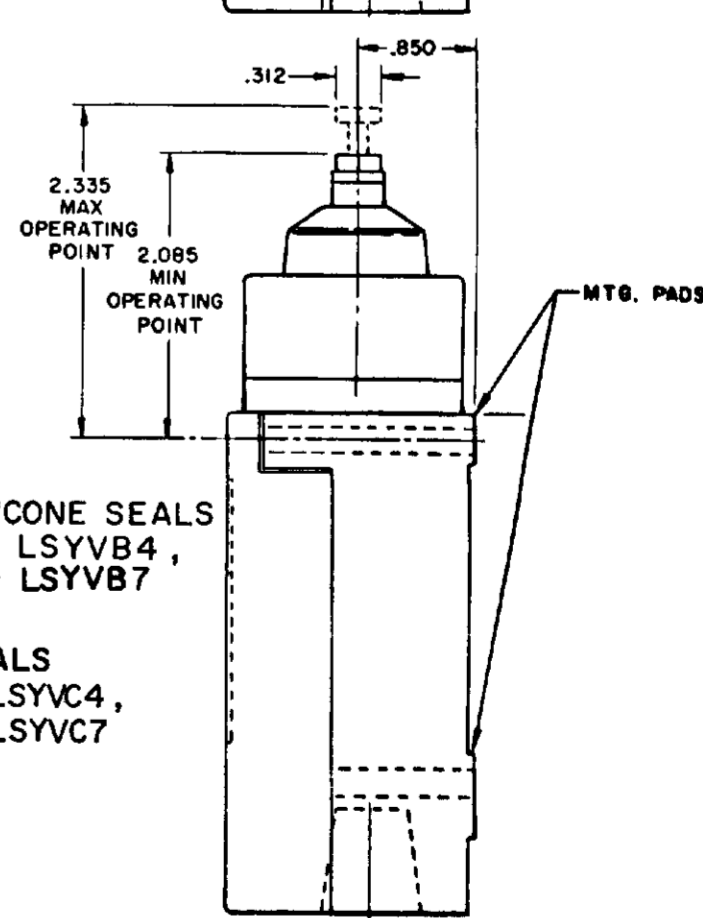
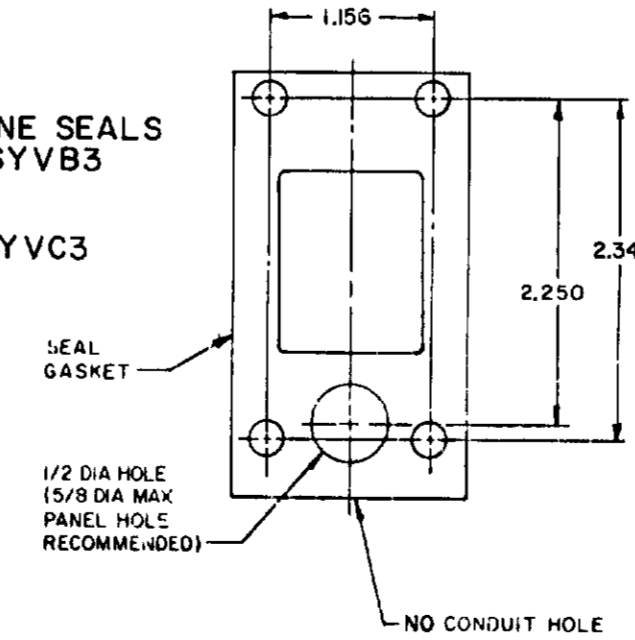

MICRO SWITCH
THIS DRAWING GOVERNS A PROPRIETARY ITEM AND IS THE PROPERTY OF MICRO SWITCH, A DIVISION OF
MONEYWELL. THIS DRAWING IS NOT TO BE COPIED OR USED WITHOUT THE APPROVAL OF MICRO SWITCH.
A DIVISION OF MONEYWELL
180 W. 50th ST. NEW YORK, N.Y. 10018

SWITCH - ENCLOSED

LSY SERIES
CHART 1

SCALE NONE
DO NOT SCALE PRINT

NOTES:
1 - ALL UNITS AVAILABLE WITH
FLUOROSILICONE AND VITON SEALS